

SOLIDWORKS WORLD 2015

FEBRUARY 8-11
PHOENIX CONVENTION CENTER | PHOENIX, AZ

SOLIDWORKS Composer: As Easy as Building with LEGOs®

Brian Reel, Field Tech Services Manager
Jordan Nardick, Application Engineer
Computer Aided Technology, Inc.



Agenda

Introduction to the User Interface

Creating Views

Creating High Resolution Images

Adding Special Effects

Design Changes

Q & A

User Interface...

SOLIDWORKS
WORLD 2015



SOLIDWORKS | DASSAULT SYSTEMES | The 3DEXPERIENCE Company

SOLIDWORKS
WORLD 2015



SOLIDWORKS | DASSAULT SYSTEMES | The 3DEXPERIENCE Company

SOLIDWORKS
WORLD 2015

Description	SYM	QTY
4141030	1	2
4188315	2	1
4210033	3	2
4210094	4	1
4220462	5	1
4228178	6	2

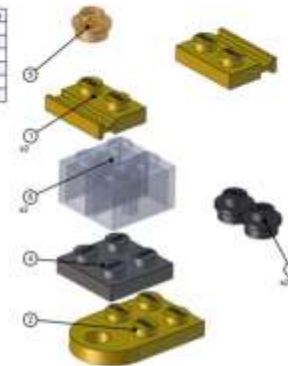

SOLIDWORKS | DASSAULT SYSTEMES | The 3DEXPERIENCE Company

User Interface...

- AVI Animations
- SVG/HTML Web Pages
- PDF Direct

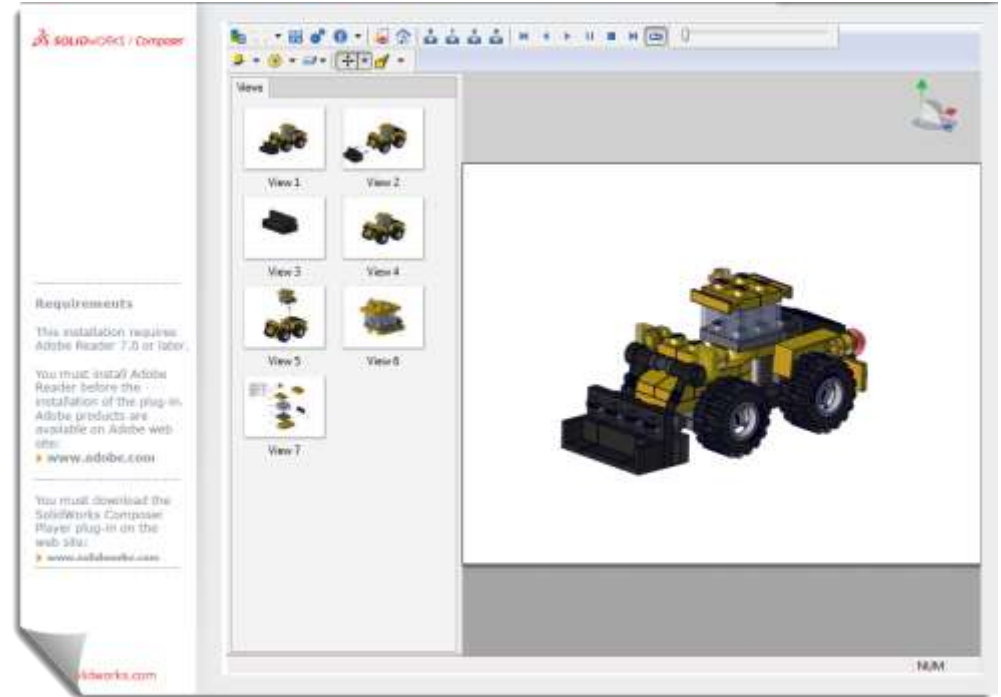

User Interface...

SOLIDWORKS vs. COMPOSER Mouse Control



Our First View...

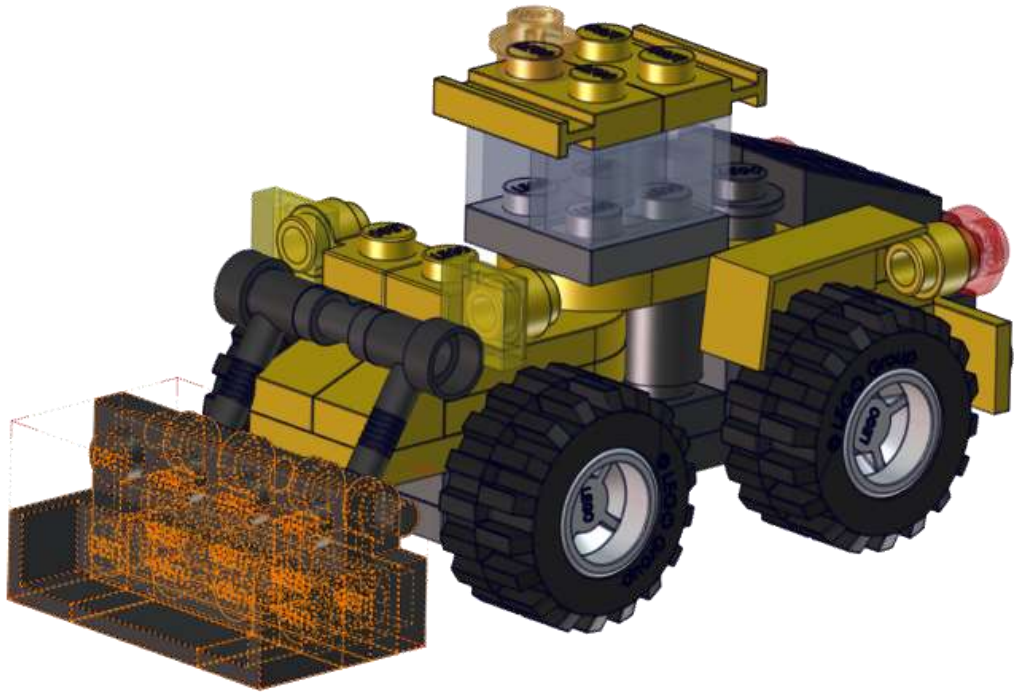
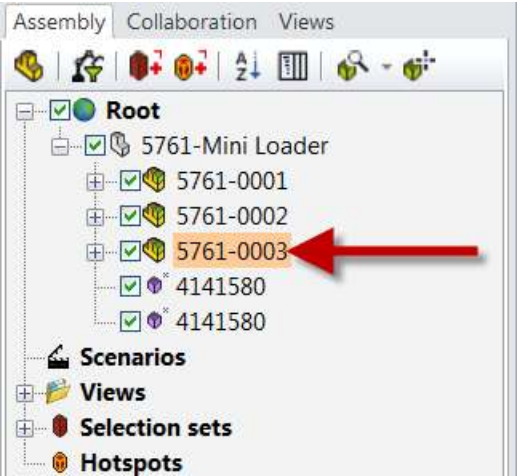

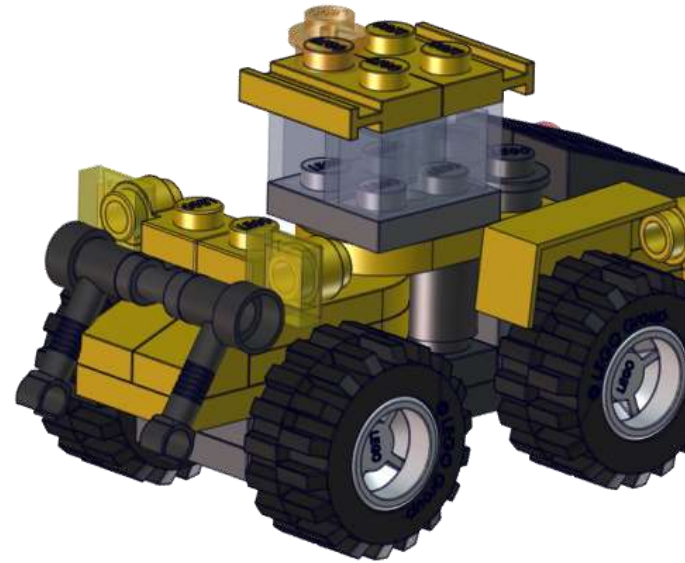
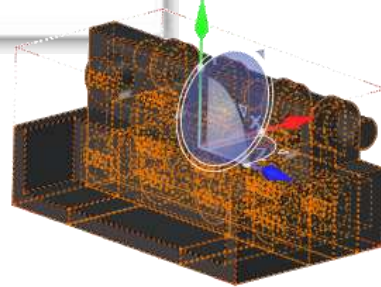
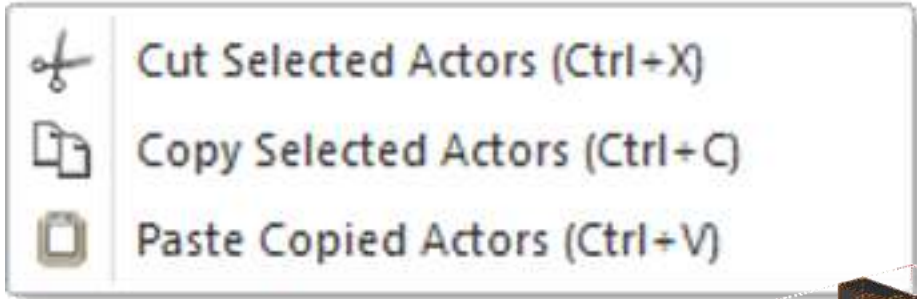
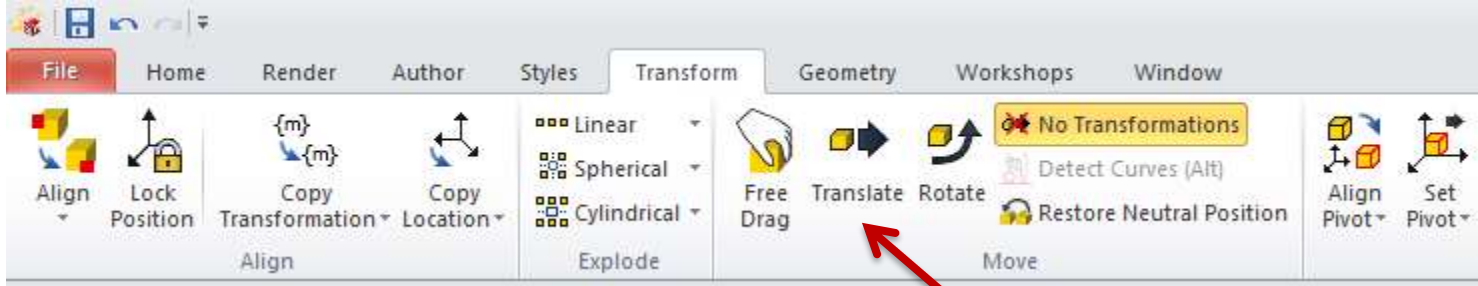

or Ctrl + E

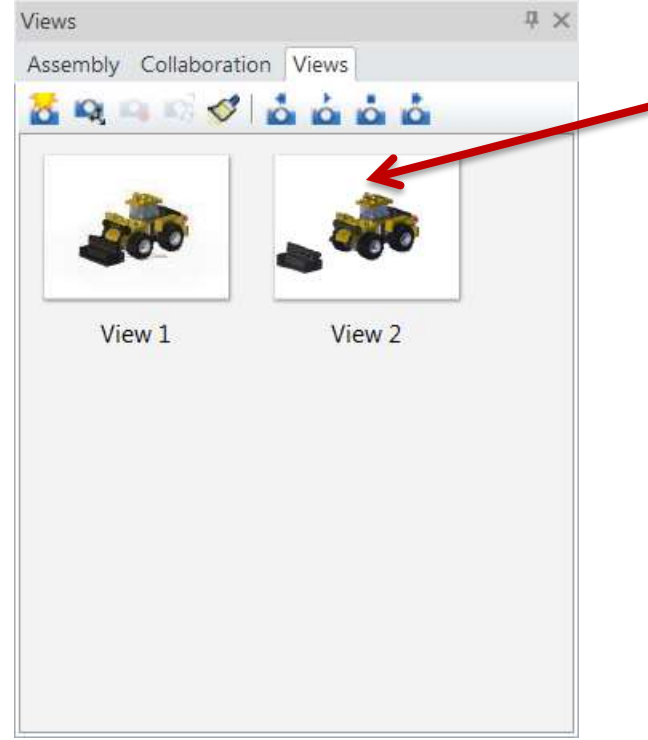
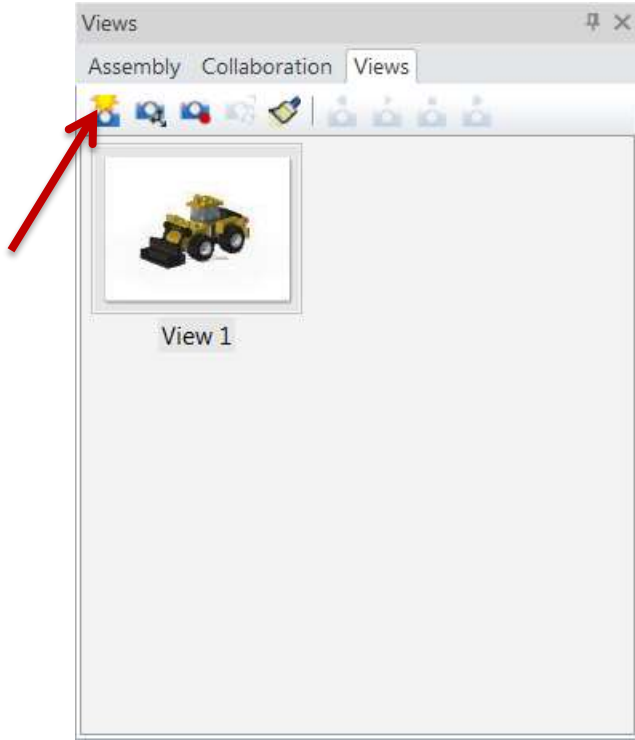

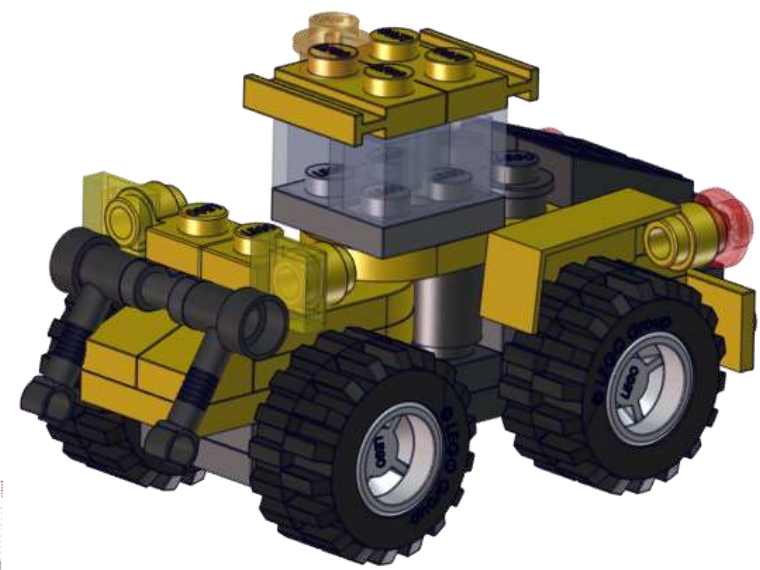
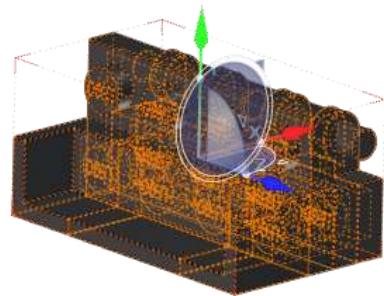
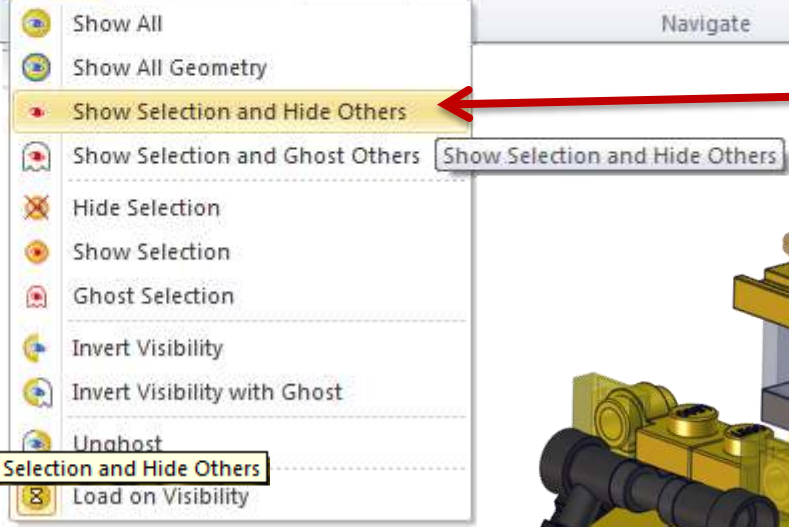
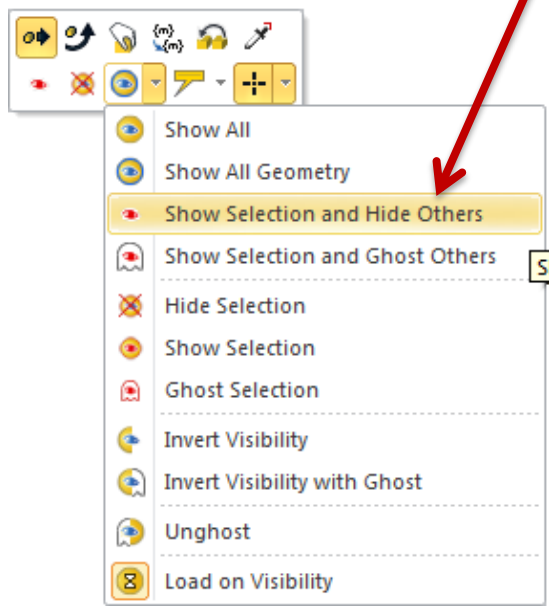

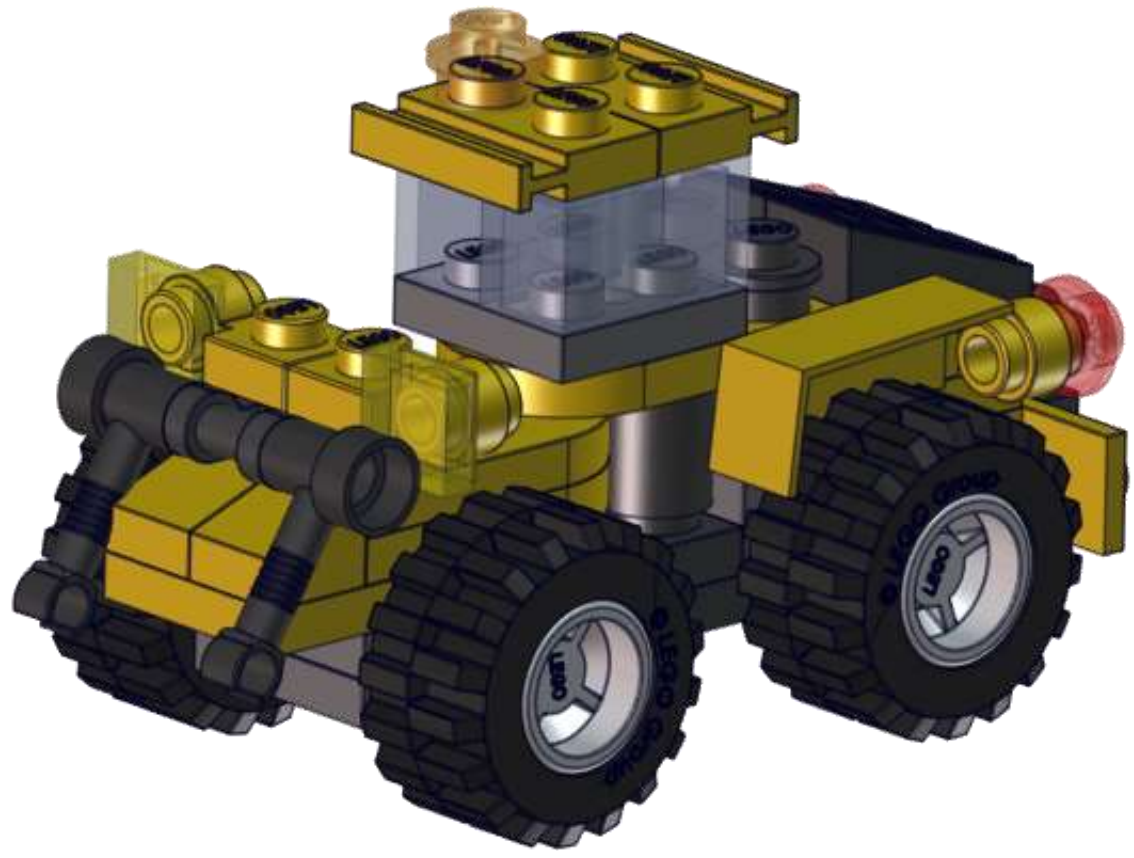
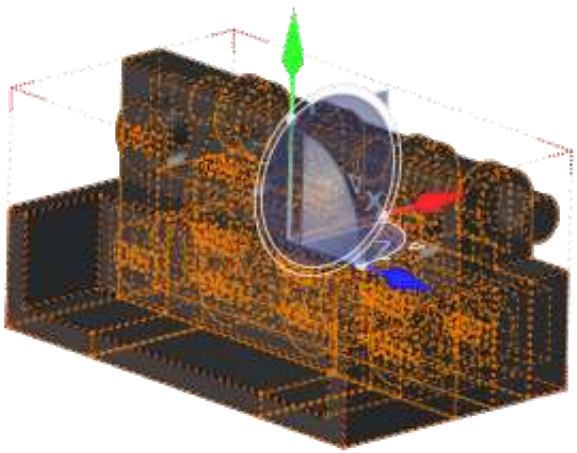

or Ctrl + E

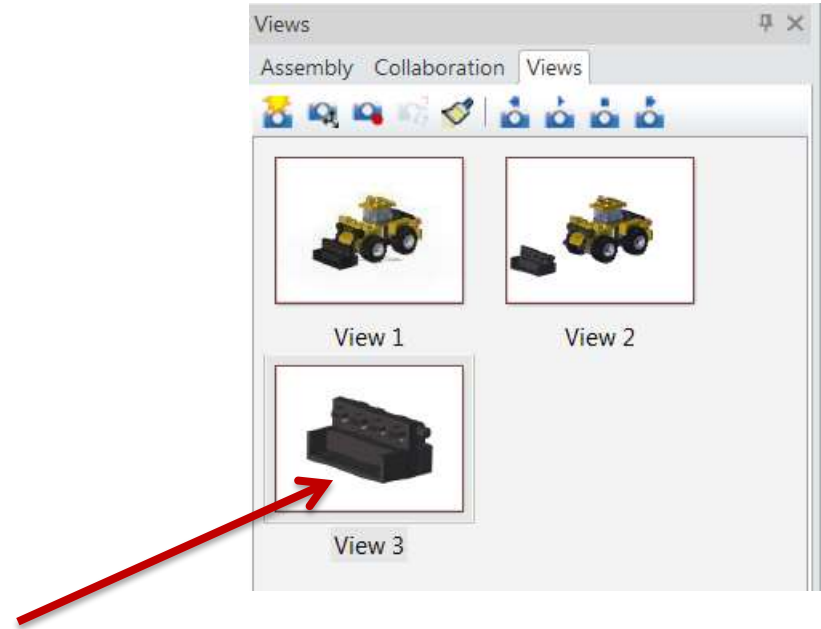
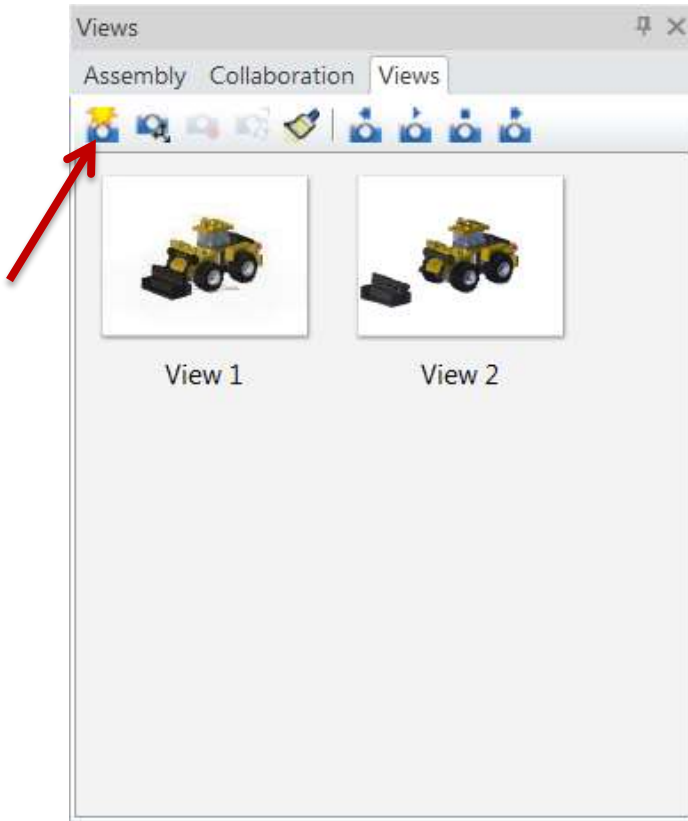



- Show All
- Show All Geometry
- Show Selection and Hide Others
- Show Selection and Ghost Others
- Hide Selection
- Show Selection
- Ghost Selection
- Invert Visibility
- Invert Visibility with Ghost
- Unghost
- Load on Visibility

Show All Geometry



- Show All
- Show All Geometry
- Show Selection and Hide Others
- Show Selection and Ghost Others
- Hide Selection
- Show Selection
- Ghost Selection
- Invert Visibility
- Invert Visibility with Ghost
- Unghost
- Load on Visibility



or Ctrl + E

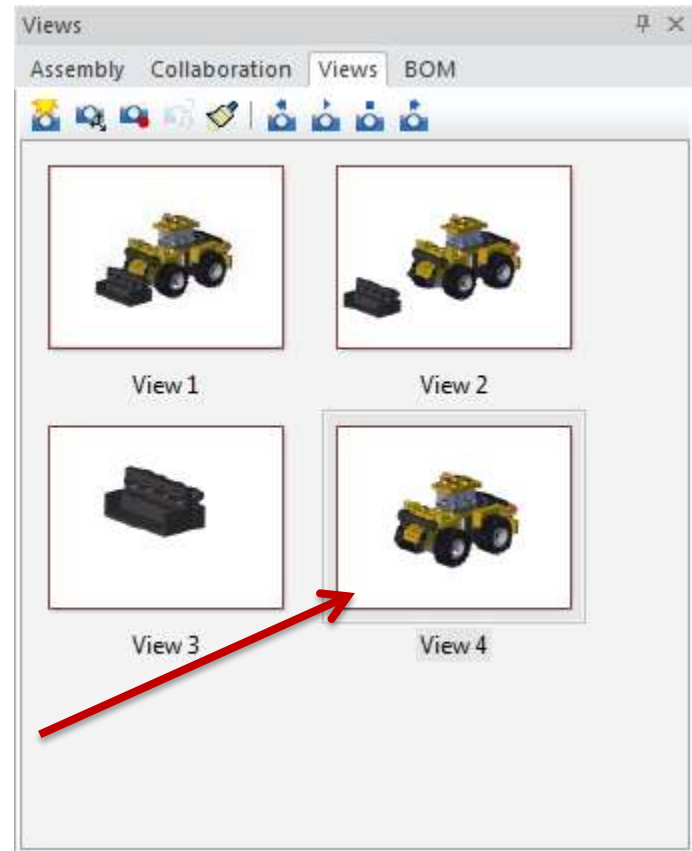
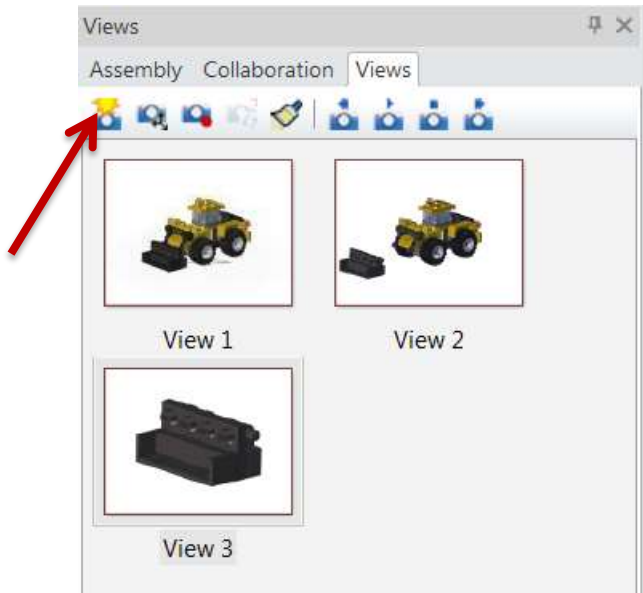

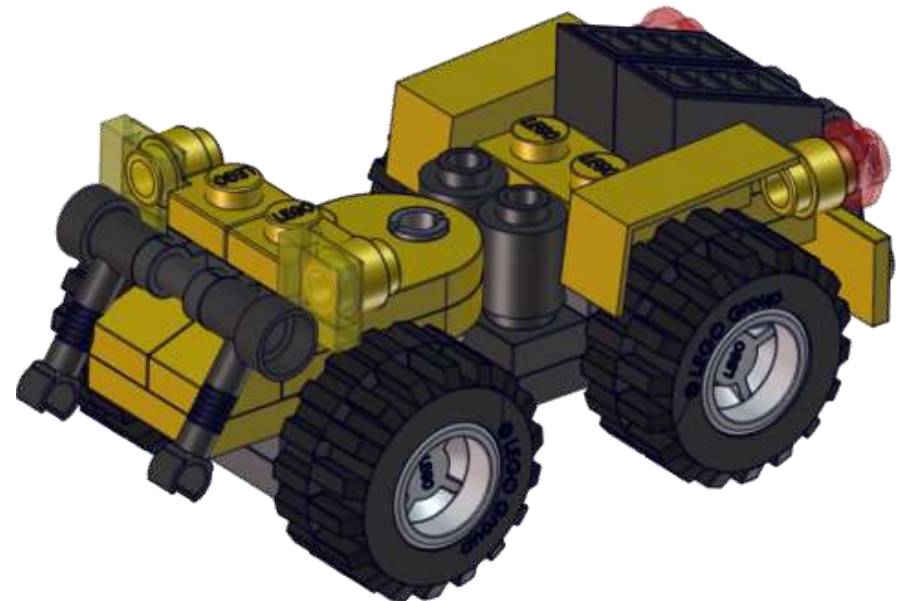
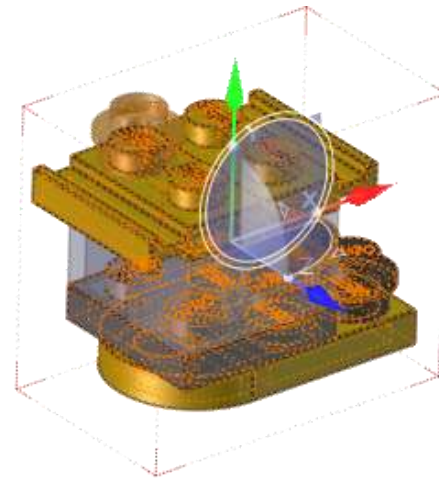
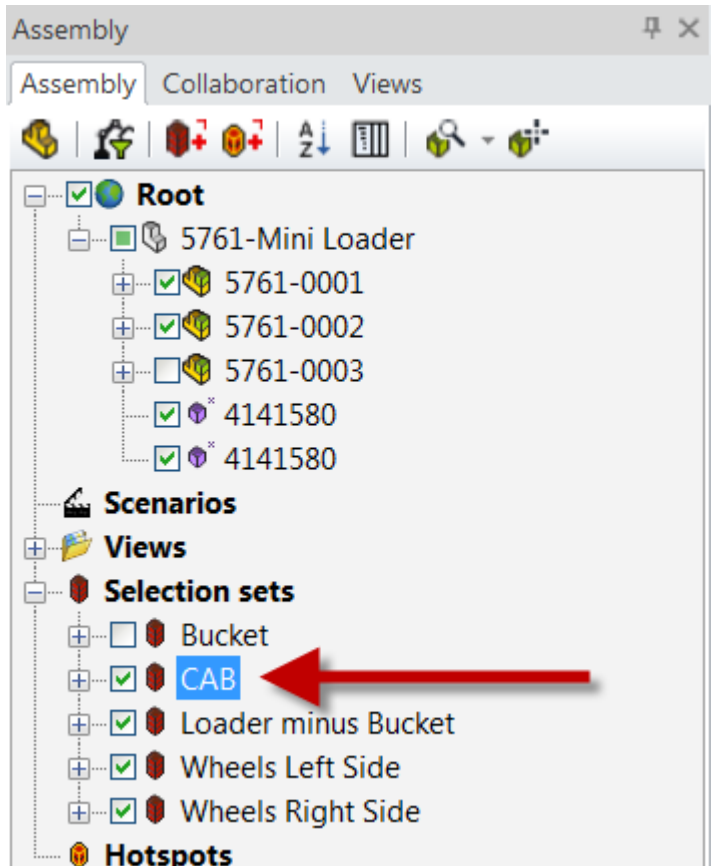

or Ctrl + E

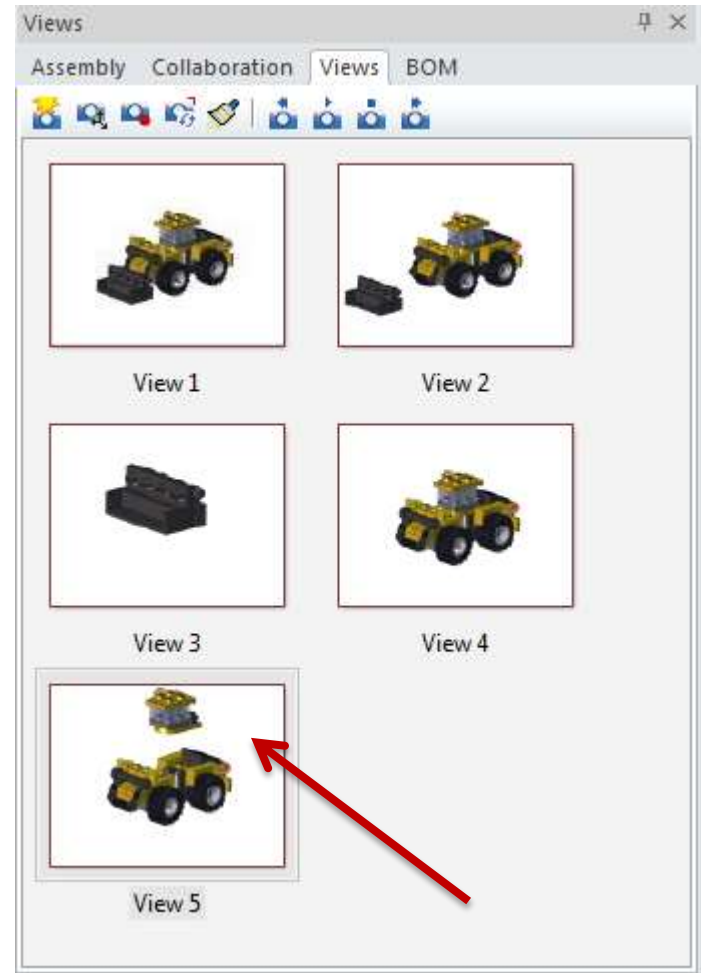
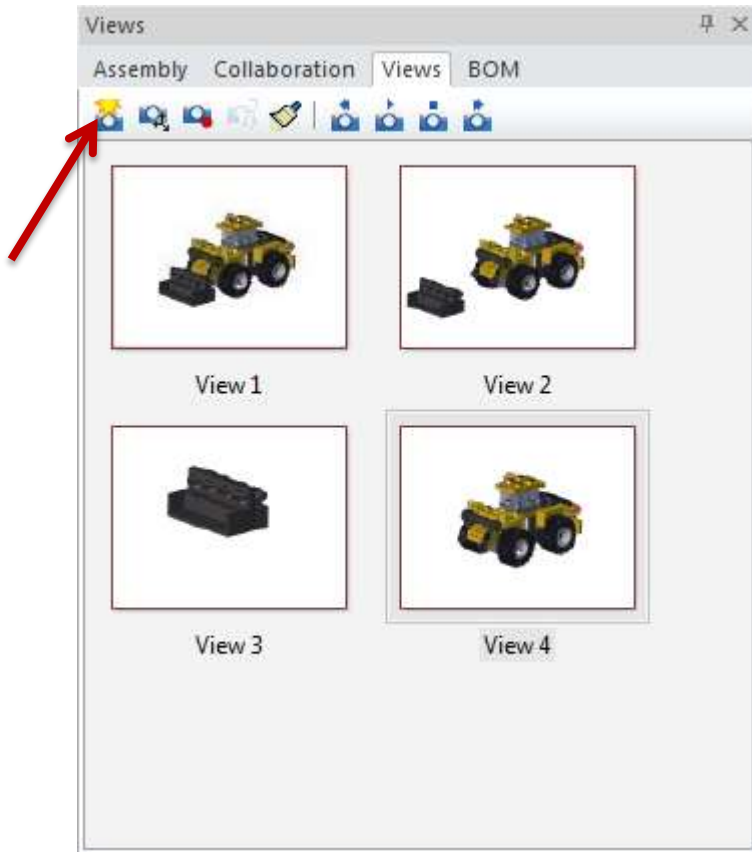

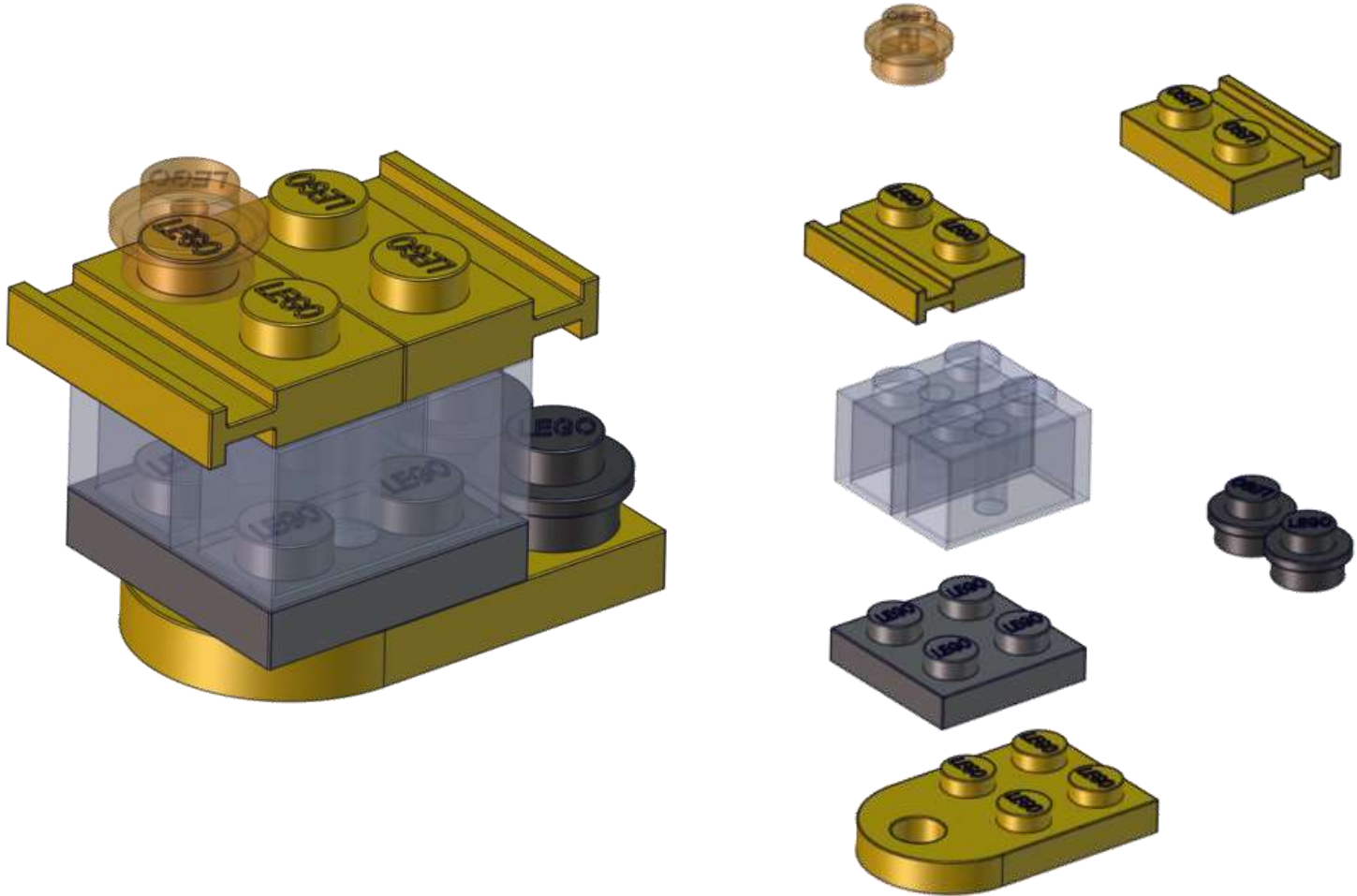



3DS.COM/SOLIDWORKS © Dassault Systèmes | Confidential Information | 2/17/2015 | ref.: 3DS_Document_2014

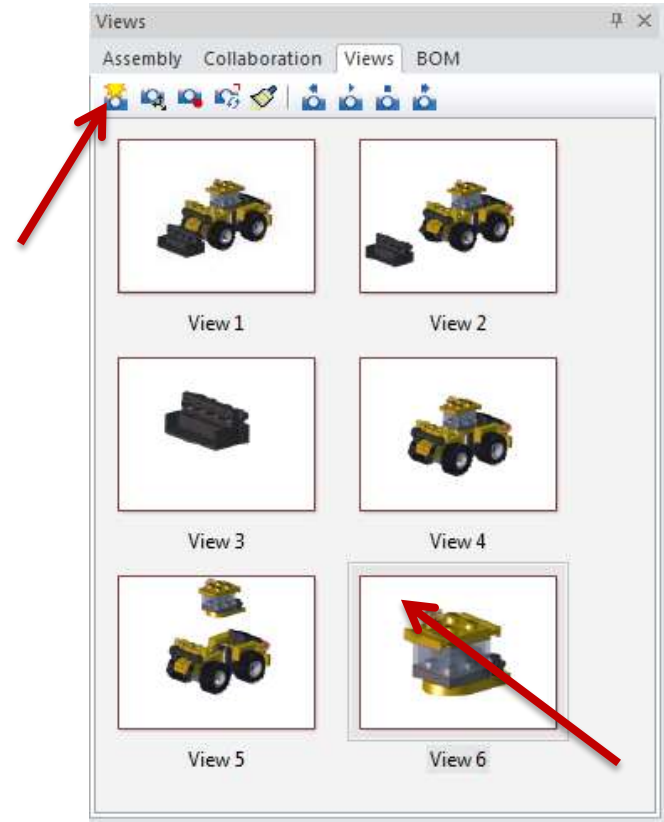
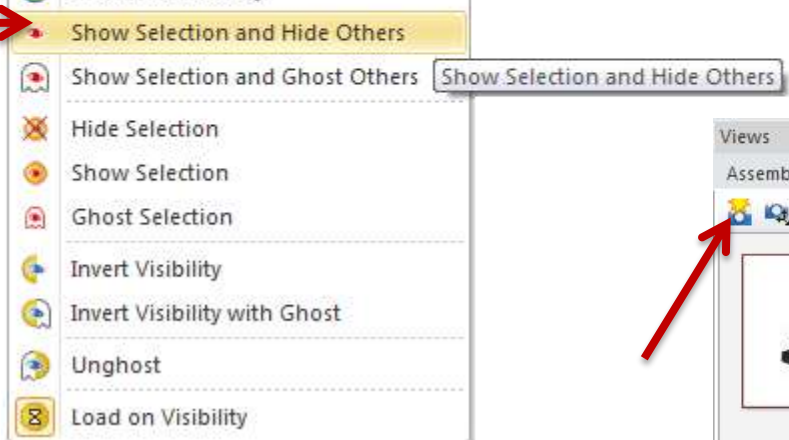
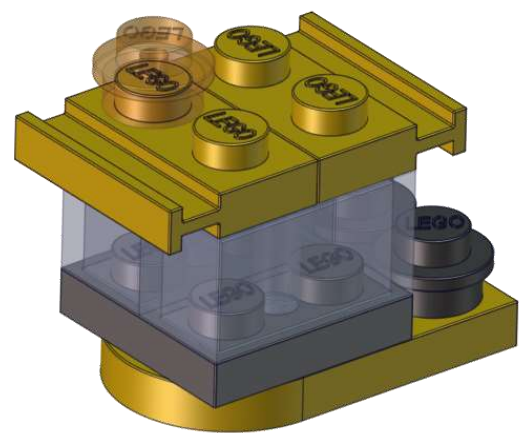

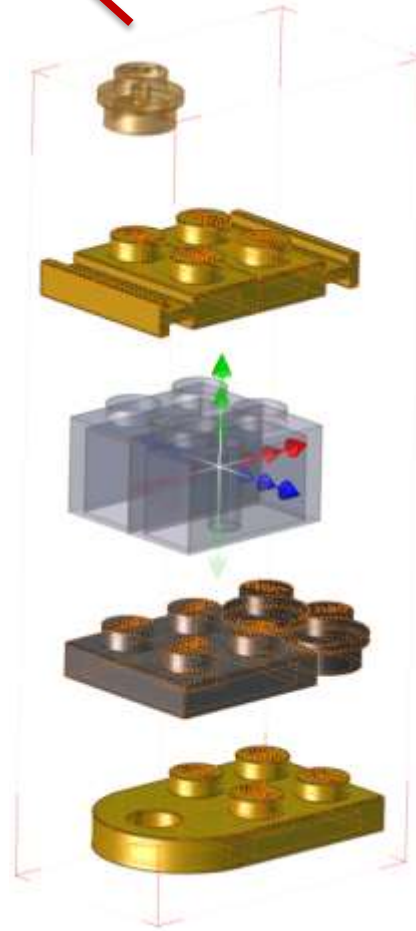

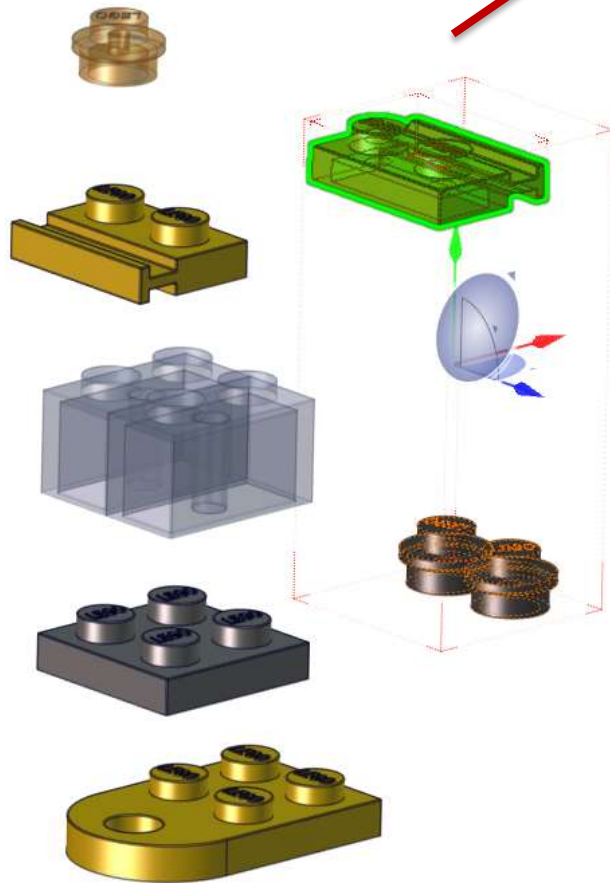
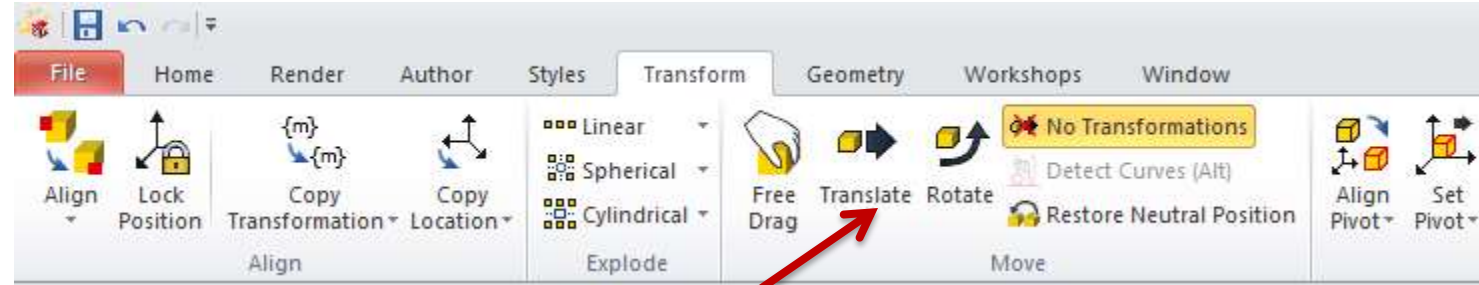

Exporting Views...

High Resolution Workshop

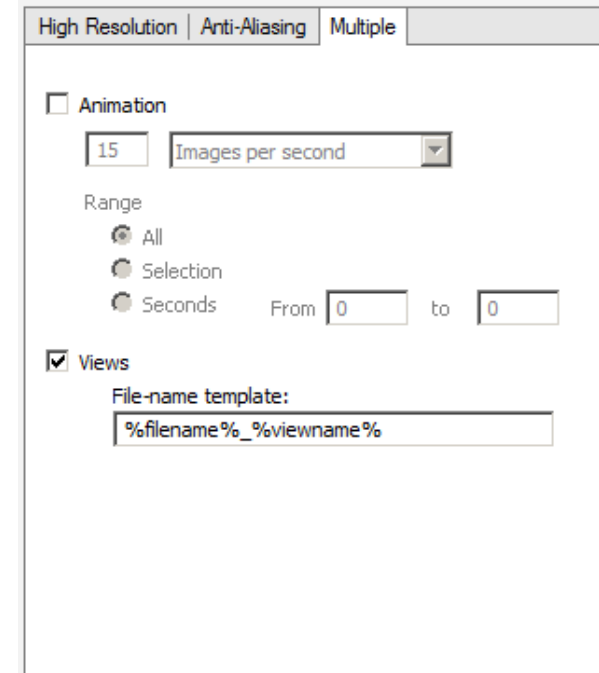
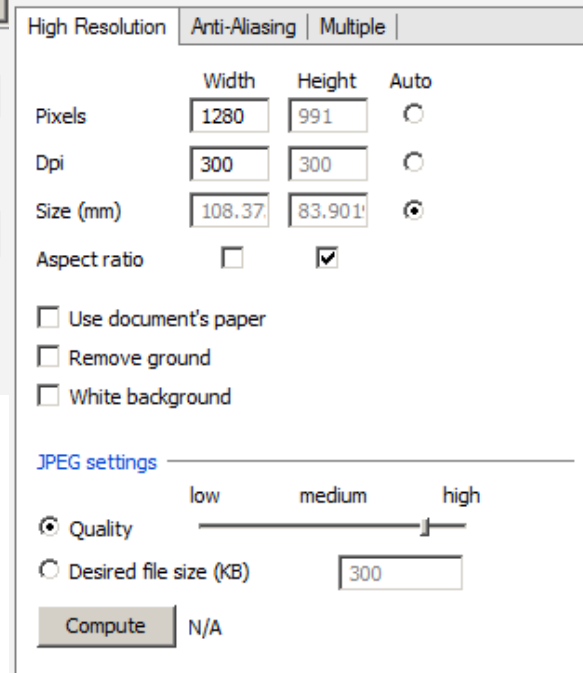
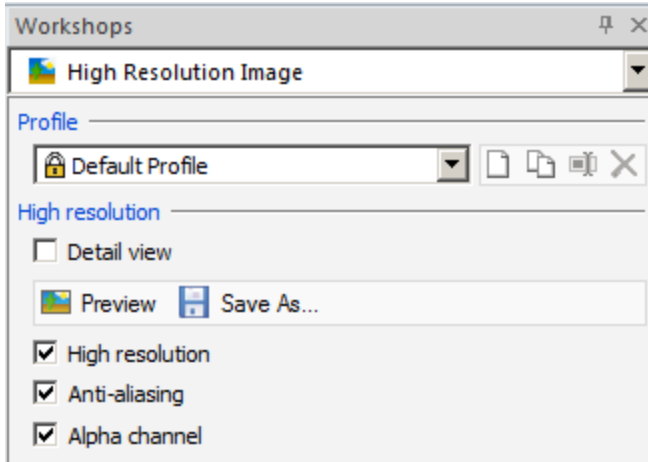



Switch to Microsoft Word

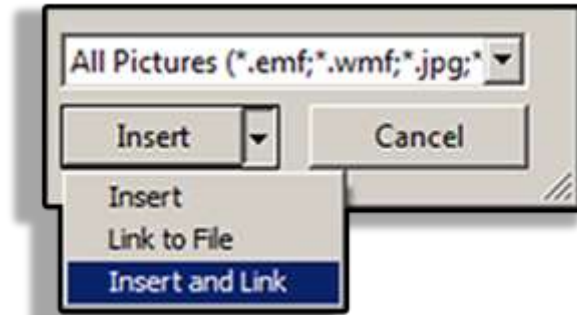
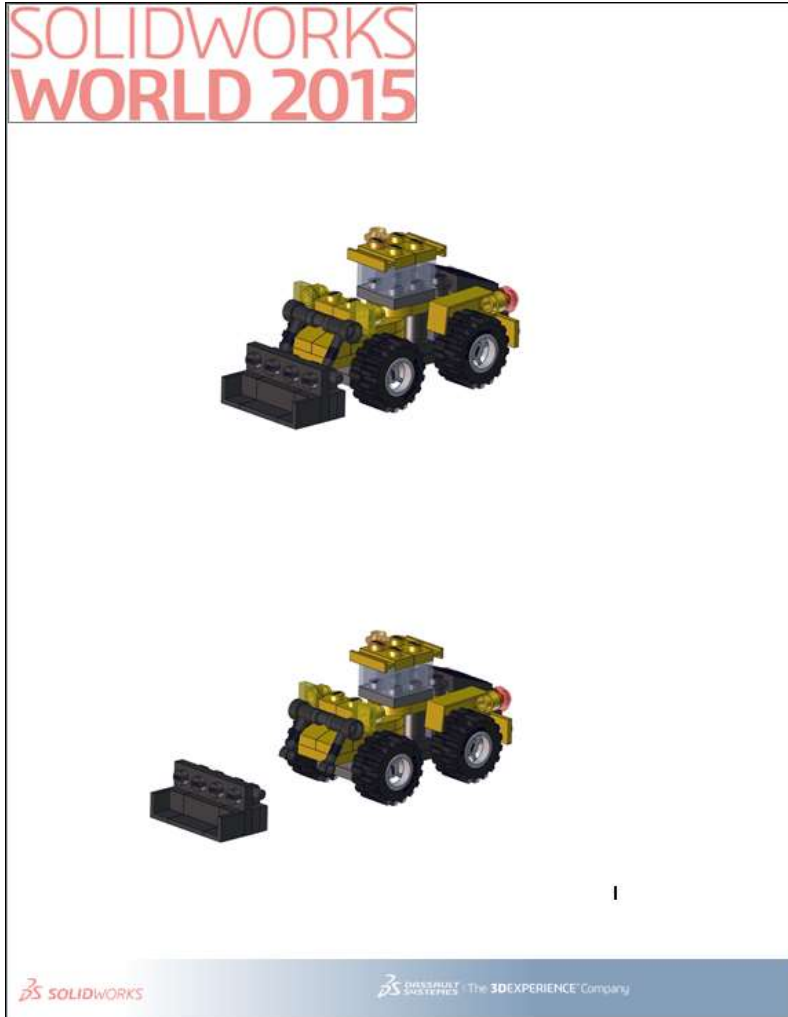



Special Effects Time



Arrows

Hint: Hold **ALT** to Axis Lock

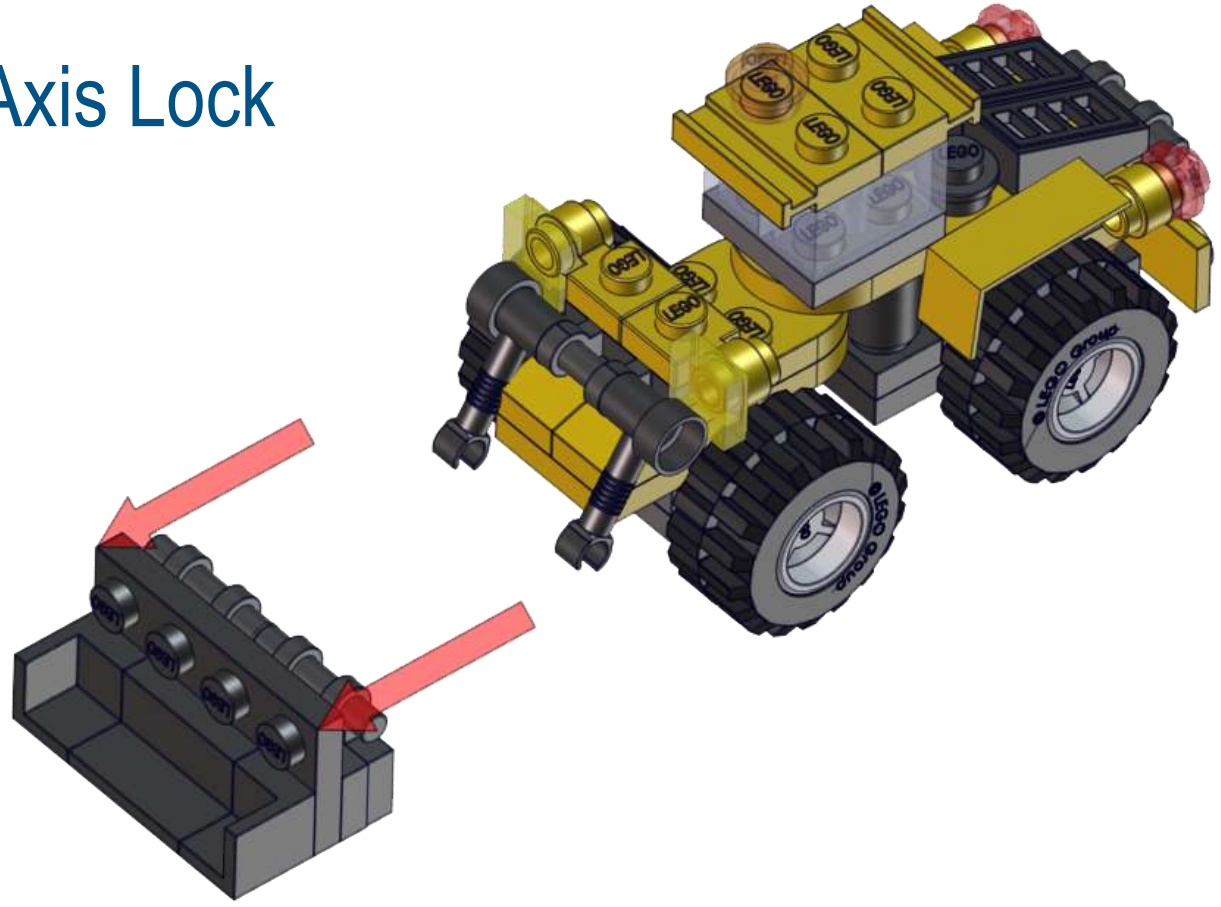

3DS.COM/SOLIDWORKS © Dassault Systèmes | Confidential Information | 2/17/2015 | ref.: 3DS_Document_2014

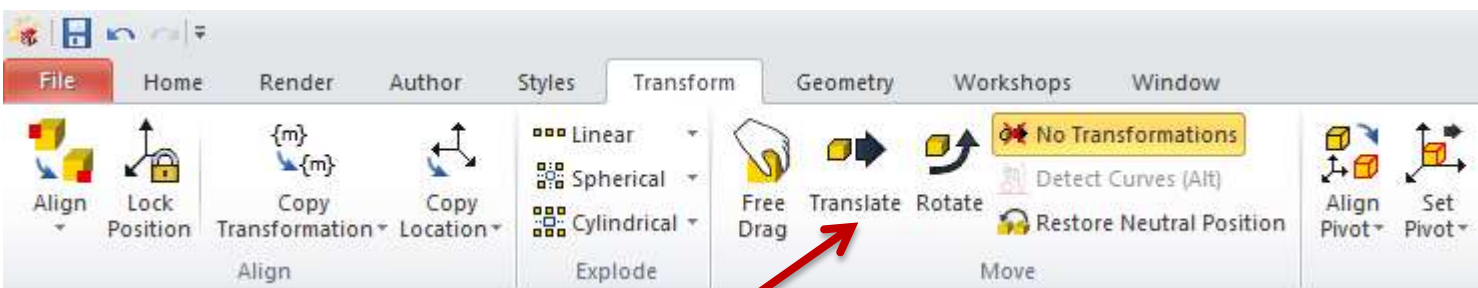

Arrows Right Click and Translate



- Cut Selected Actors (Ctrl+X)
- Copy Selected Actors (Ctrl+C)
- Paste Copied Actors (Ctrl+V)

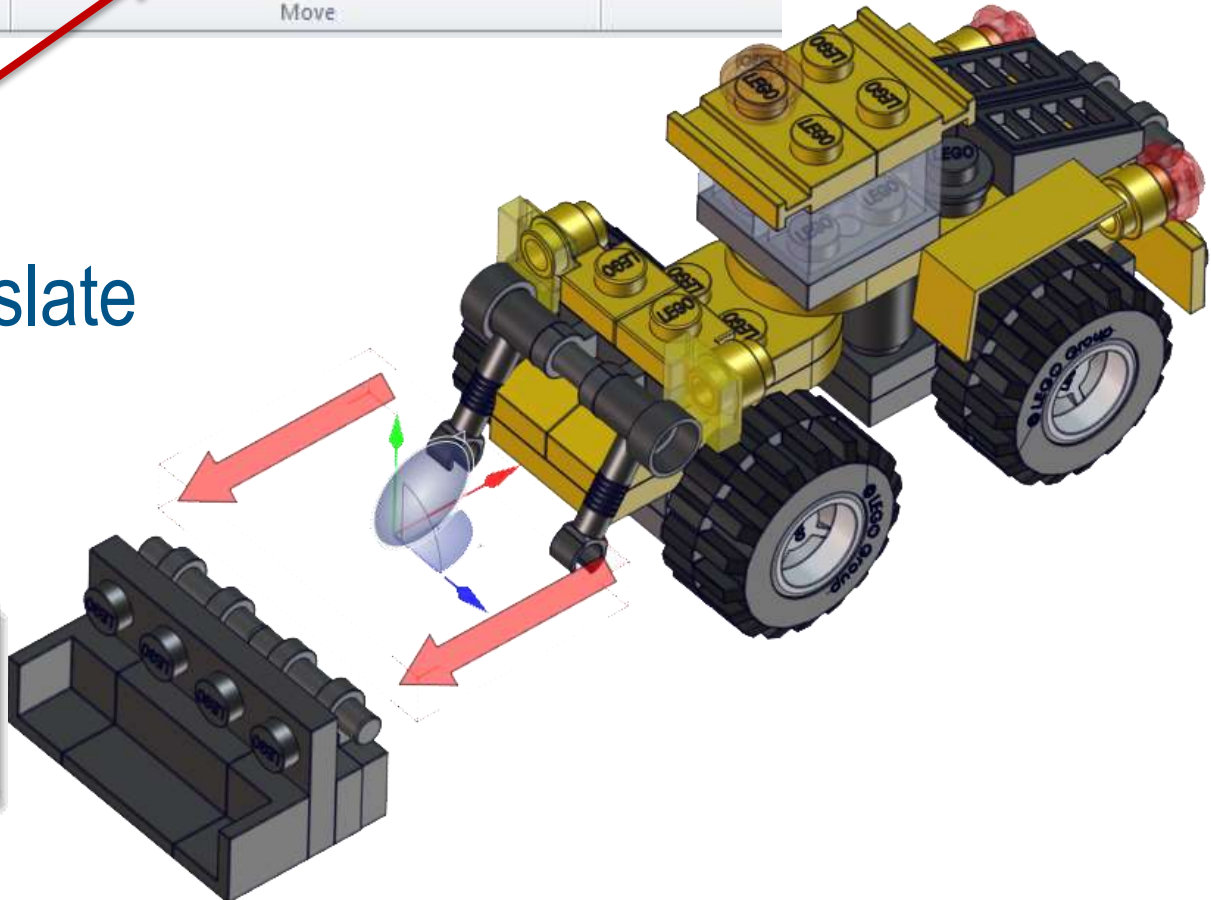

Arrows

Properties to edit appearance

Properties

Tooltip Name (Actor.Name)

Opacity 255

Stay on top Enable

Arrow shape

Extremity Start

Head shape 0.00

Head width 0.107

Head length 0.214

Width 0.107

Length 1.000

Background

Color

Gradient Enable

Opacity 214

Border

Show Enable

Width 0.50

Opacity 255

Color

Type

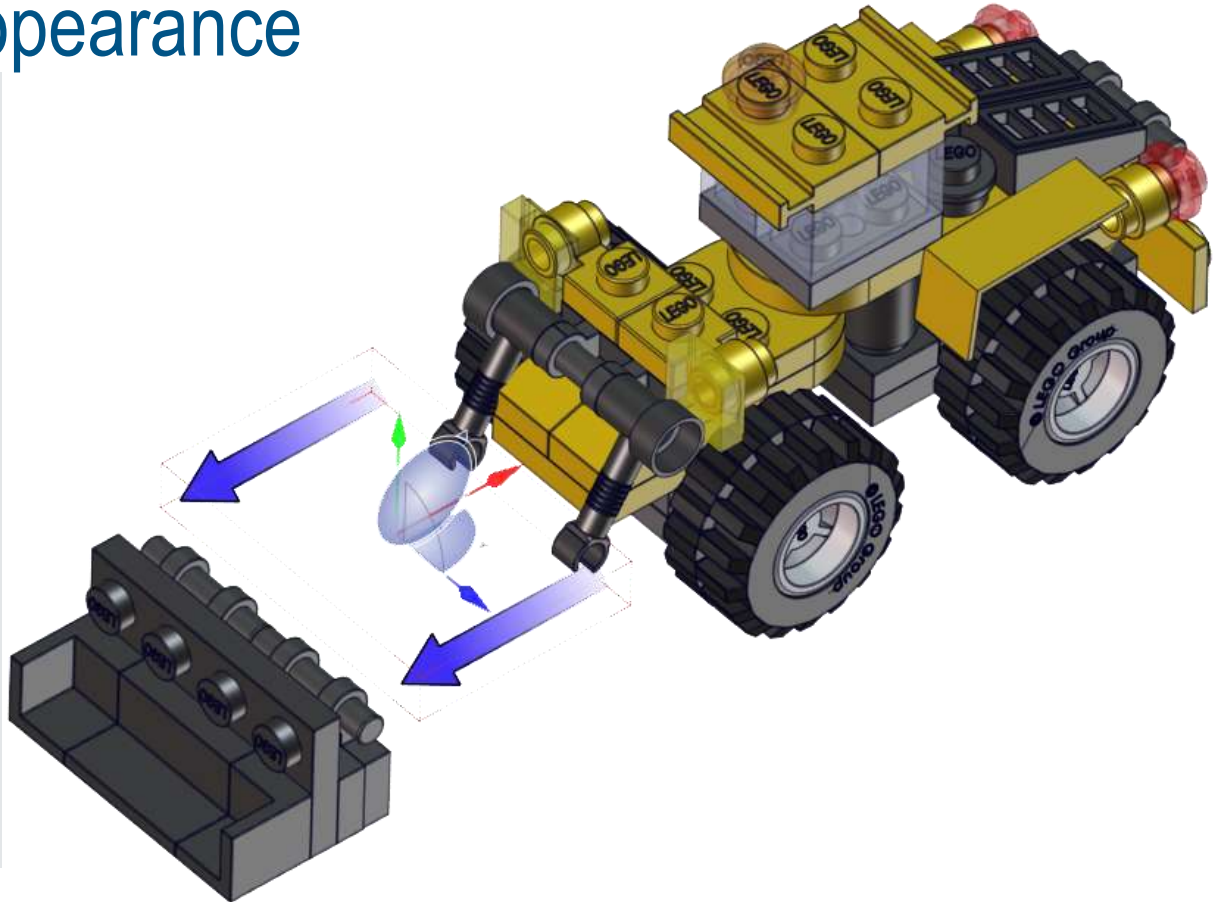

Very Important to Update View!

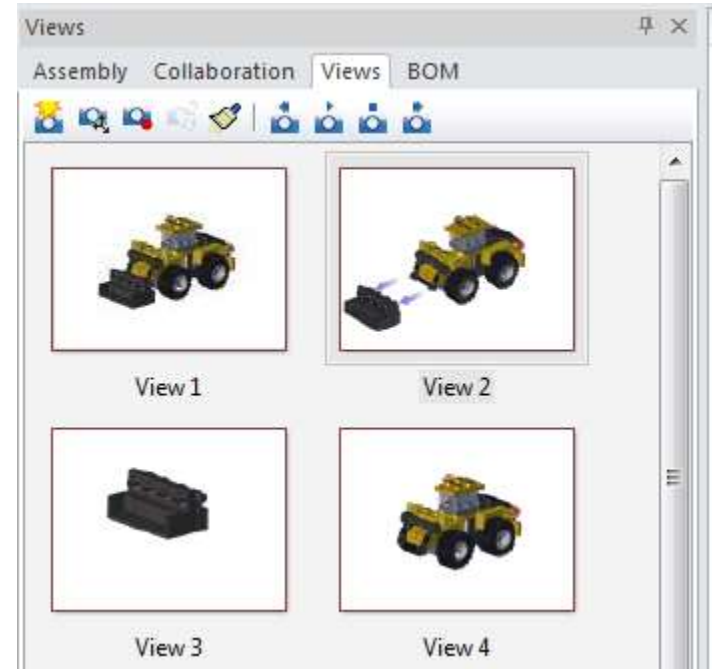
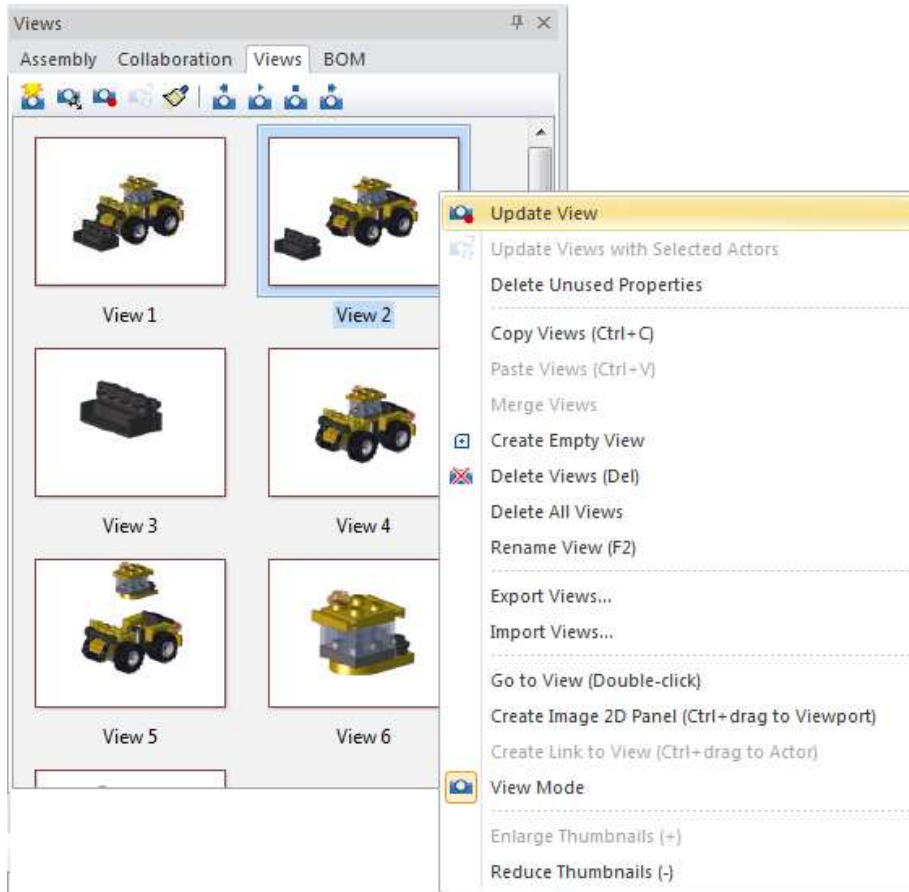

Very Important to Update View!

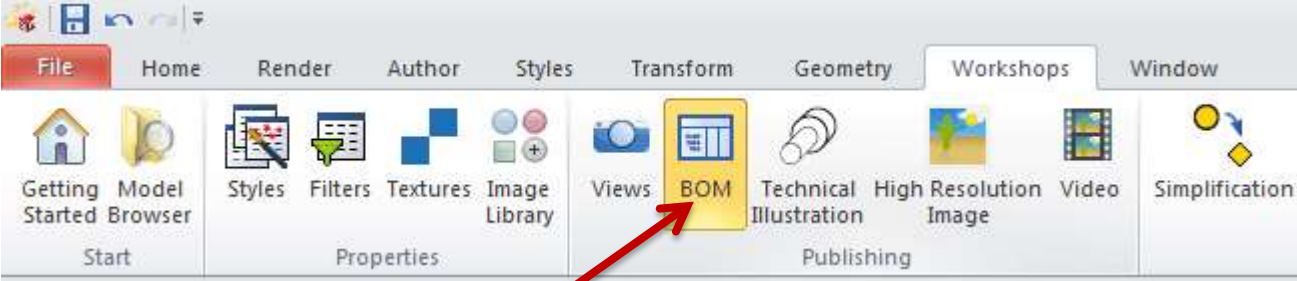

Description	BOM ID	Qty
4141630	1	2
4188313	2	1
42106333	3	2
4211094	4	1
4222960	5	1
4226179	6	2

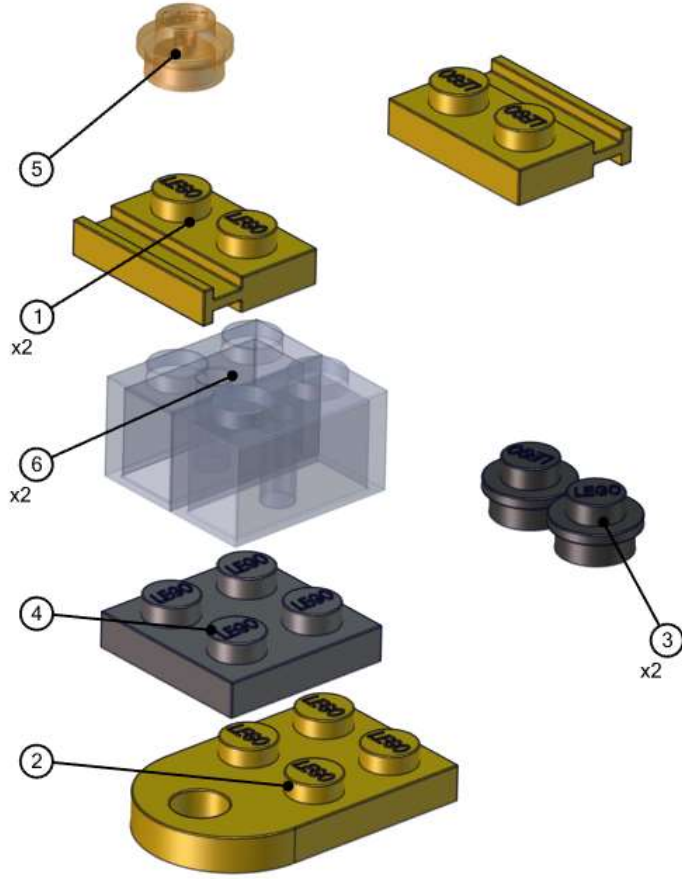

Properties

Name: BOM

Freeze: No Freeze

Opacity: 255

Model highlighting: Enable

Update:

Filter on visible callouts: Enable

Text: MS Shell Dlg (13)

Size: 13

Placement: Free

Left: -8.477

Top: 18.848

Width: 72.117

Height: 66.771

Workshops

BOM

Profile: Default BOM

BOM IDs: Apply to: Selection

Callouts:

Options: Definition | BOM ID Format | Callouts

Parent level: Level 0

Property name: Name (Actor.Name)

Compare property

Skip characters from right: 3

Ignore numerical suffix

Match case

Compare geometry

Exact

By similarity

low ————— high

Check coordinate system

Assign unique BOM IDs

3DS.COM/SOLIDWORKS © Dassault Systèmes | Confidential Information | 2/17/2015 | ref.: 3DS_Document_2014

Uh Oh! An Engineering Change...

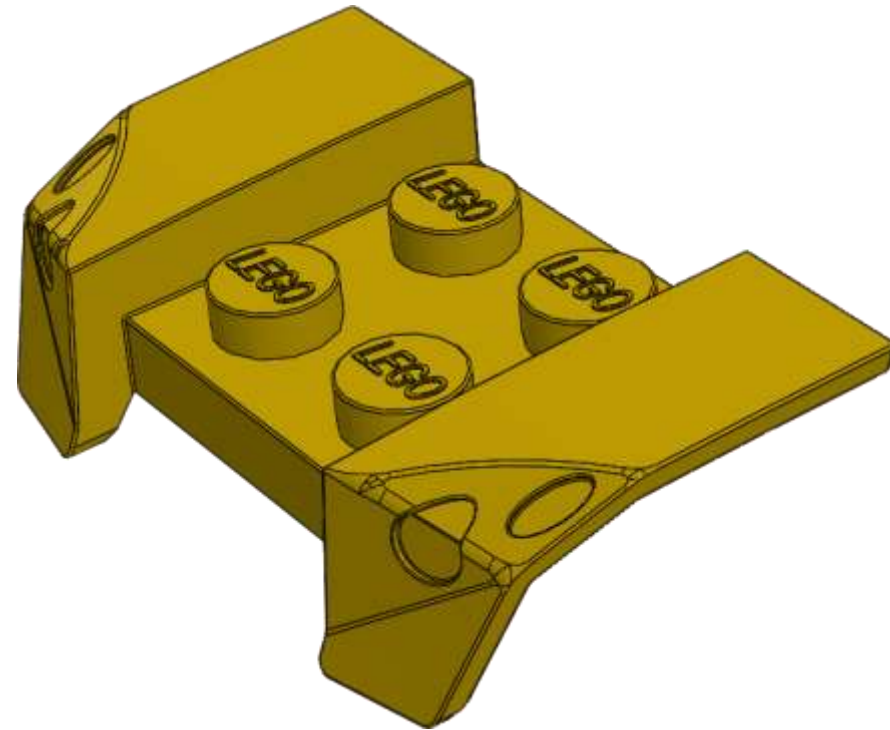
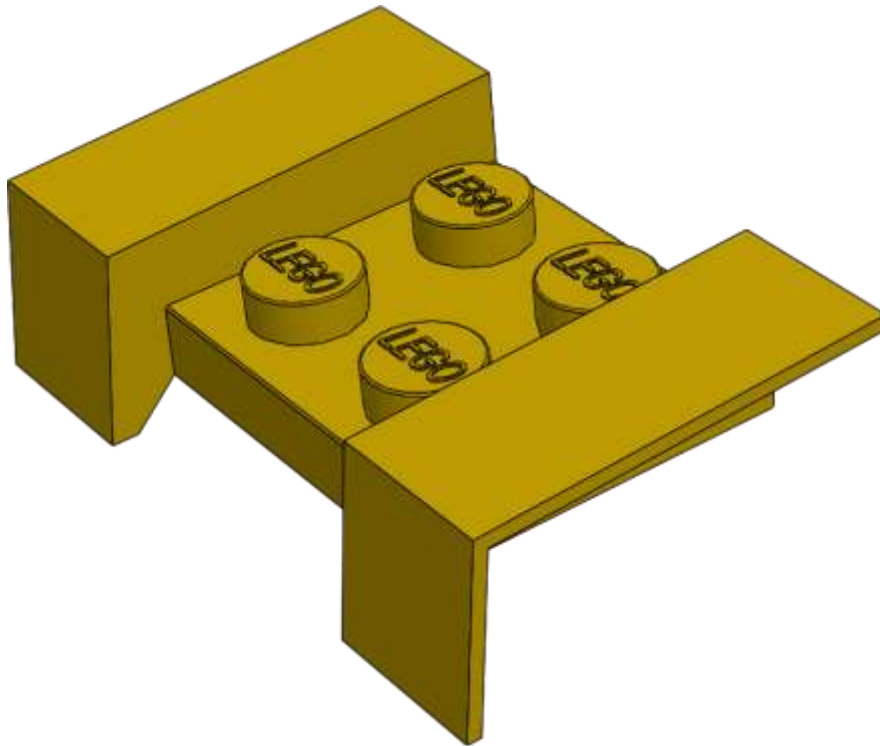

Composer Update...

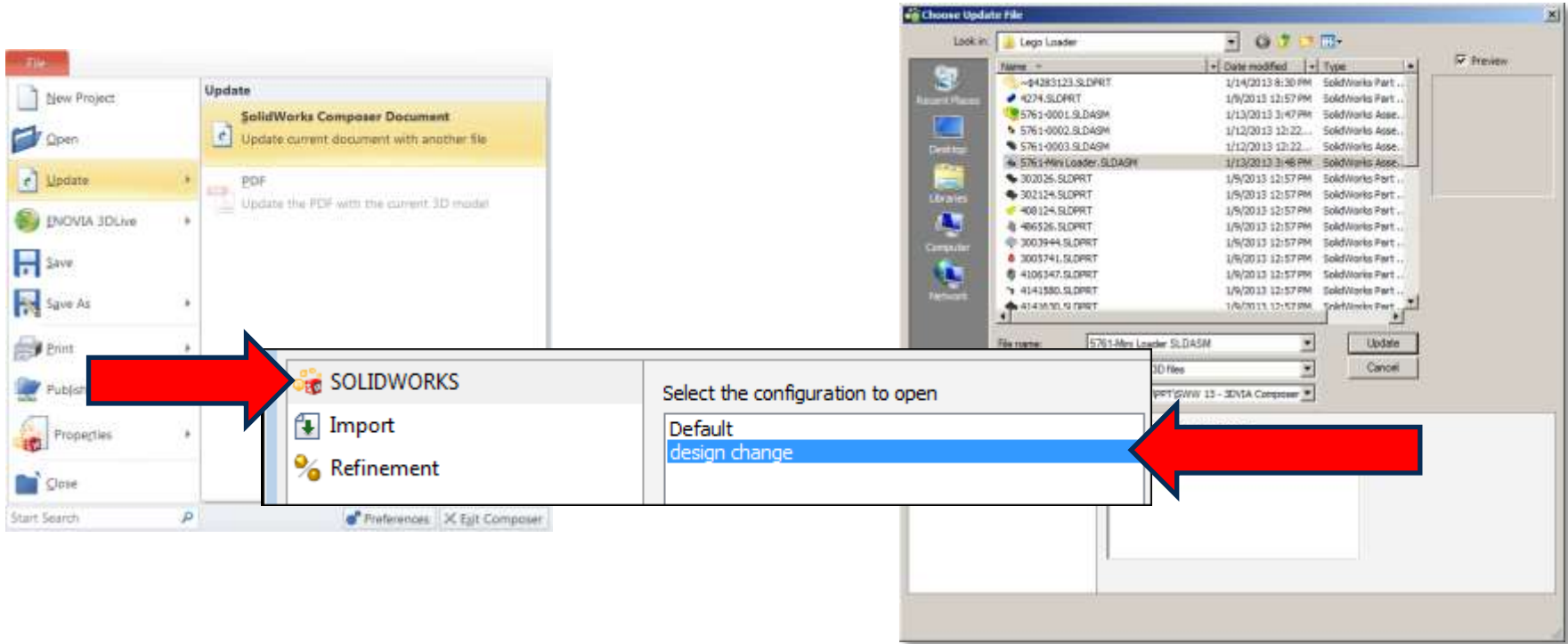

Check the Import Settings...

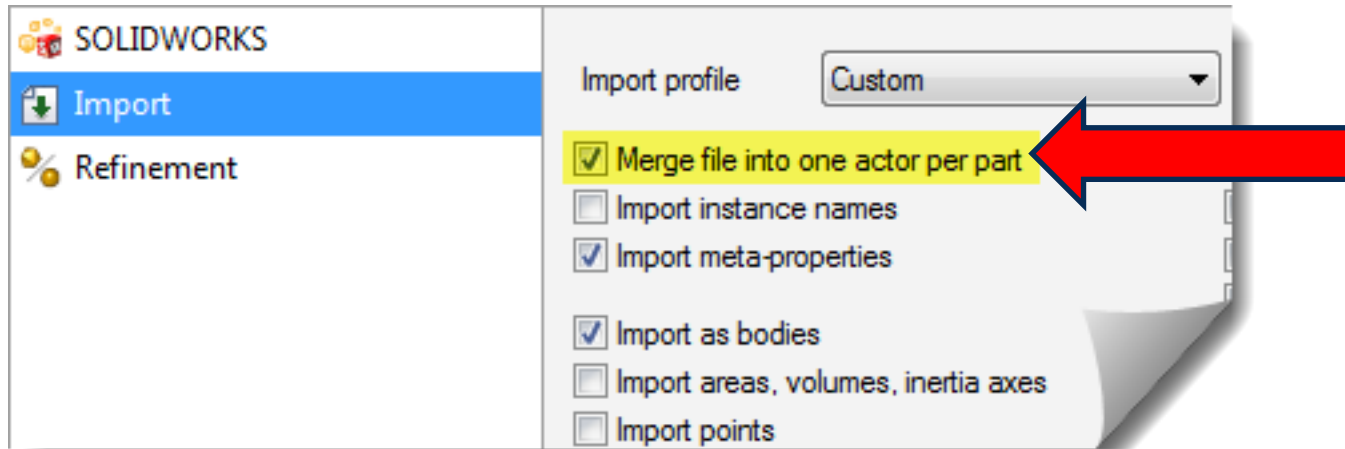

Composer Updated!

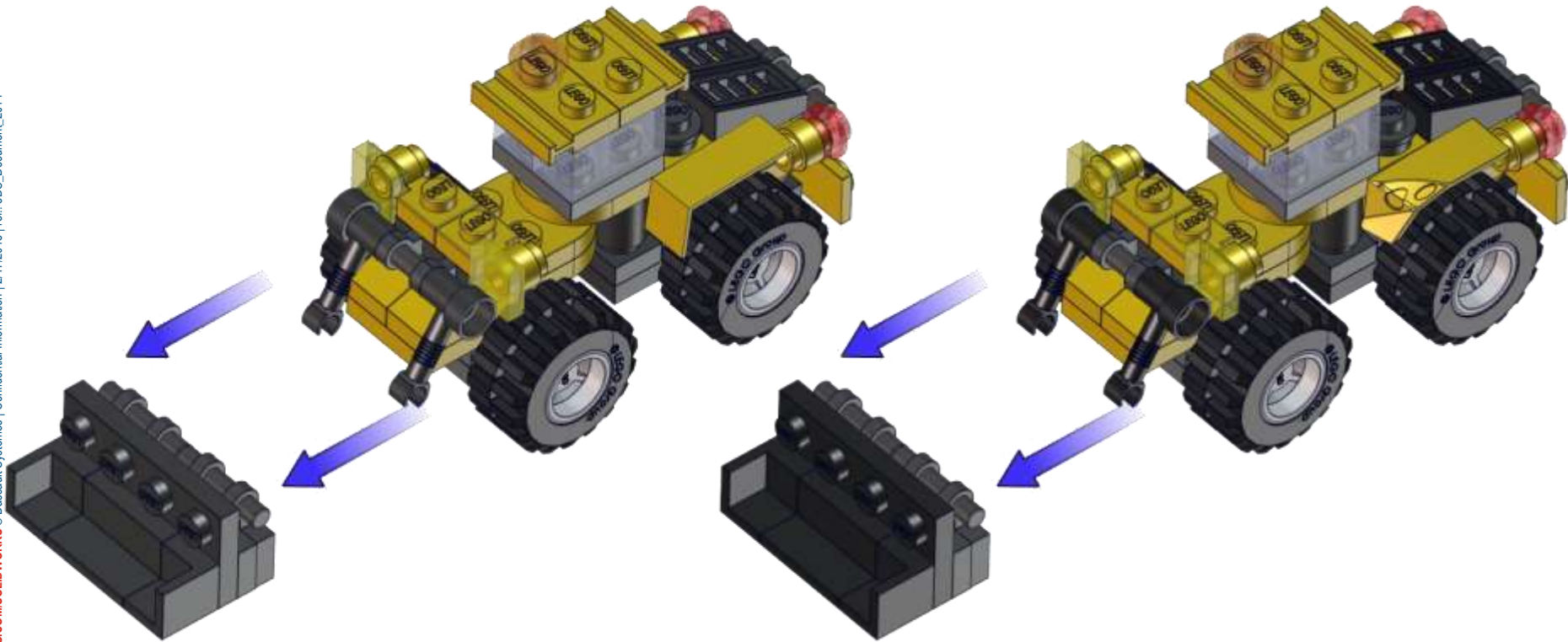

High Resolution Workshop...Re-Save Views

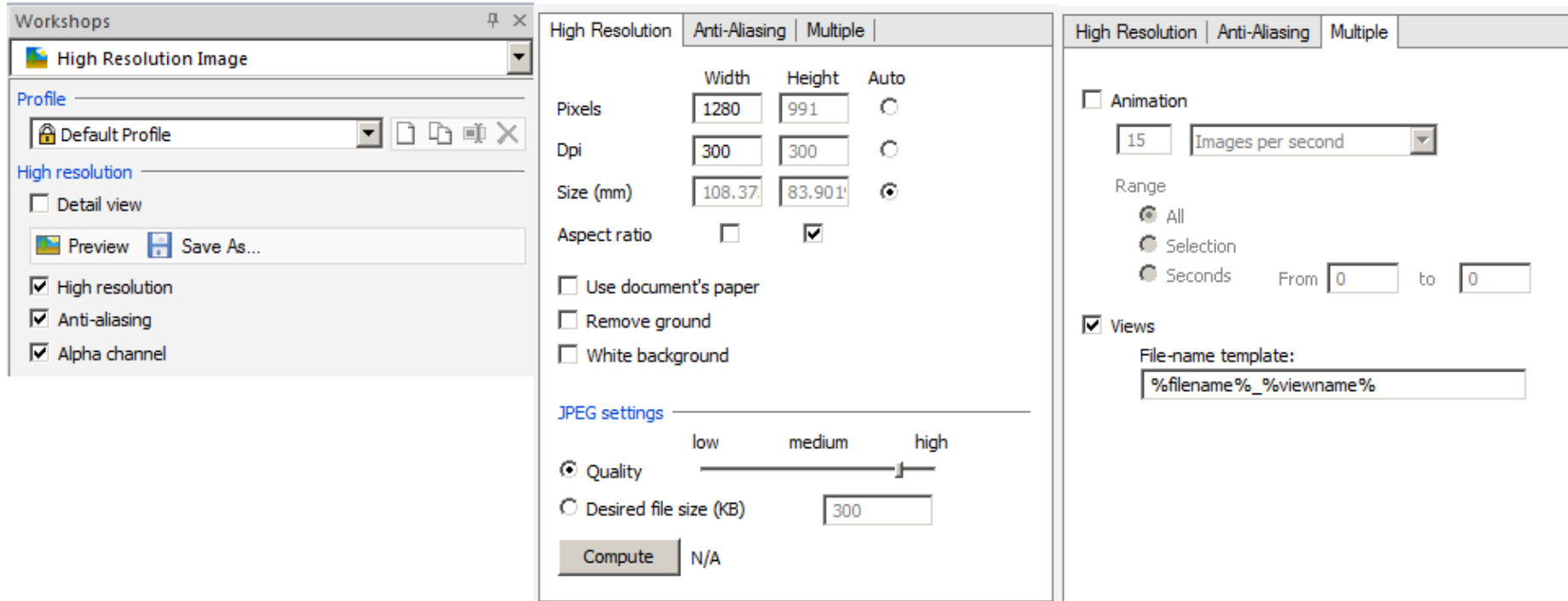

Update the Word Document

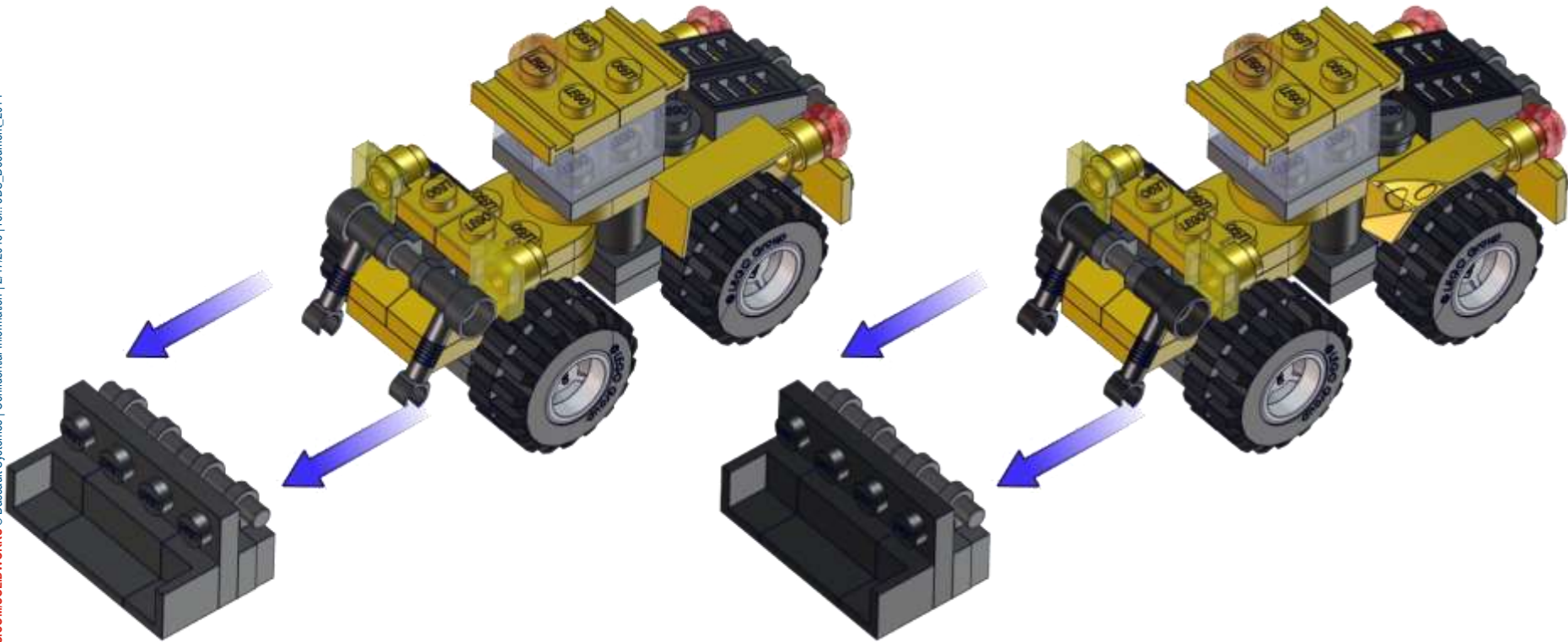

Q & A...

Go to Mobile SW World App:
Training Sessions, Name of Session, Take Survey button

Brian Reel, Field Technical Services Manager

Computer Aided Technology, Inc.

Brian.Reel@cati.com



THANK YOU!

Jordan Nardick, Applications Engineer

Computer Aided Technology, Inc.

Jordan.Nardick@cati.com



CATI and InFlow Presentation Schedule

Monday February, 9th

- **Discovering and Understanding SOLIDWORKS Dismissed Messages** - 1:30pm-2:30pm - Room North 229, Bryan Pawlak and Phil Whitaker
- **SOLIDWORKS Composer: As Easy as Building with Legos** - 1:30pm-2:30pm – Room North-225B, Brian Reel
- **Achieving Extreme SOLIDWORKS Performance: Hardware/Configuration** - 2:45-3:45pm - Room North-121A-C, Adrian Fanjoy and Josh Altergott
- **Configuring SOLIDWORKS Toolbox** - 2:45-3:45pm - Room North-124A/B, John Van Engen
- **Successfully Prepare for Your EPDM File/Data Migration** - 2:45-3:45pm - Room North-120B-C, Jeff Barker

Tuesday February, 10th

- **SOLIDWORKS Duct Tape & Bailing Wire: Creative Solutions to Everyday Problems**- 1:30-2:30pm - Room North 129A/B, Josh Altergott and Adrian Fanjoy
- **Drawings: Setup of Templates and Sheet Formats**- 1:30-2:30pm - Room North-221, Jim Krivoshein
- **EPDM Web: Implementing and Configuring** - 1:30pm-2:30pm - Room North 121A-C, Justin Webster
- **How to Build and Maintain Effective Design Tables** - 2:45-3:45pm - Room North-120D, Josh Altergott
- **DriveWorksXpress Essentials Hands-On Lab** – 4:30pm-6:00pm - Room North-227C, Ryan Dally

Wednesday February, 11th

- **Achieving Extreme SOLIDWORKS Performance: Modeling Methodology** - 2:45-3:45pm - Room North-120D, Josh Altergott, and Adrian Fanjoy
- **Sharing Assemblies—Without Giving It All Away**- 2:45-3:45pm - Room North-221, Jim Krivoshein

For a copy of all CATI and InFlow presentations please go to <http://www.cati.com/sww2015>